

SERVICE INSTRUCTION

OIL LEAKAGES IN THE AREA OF THE CYLINDER BARREL FOR ROTAX® ENGINE TYPE 912 AND 914 (SERIES)

SI-912-019

SI-914-021

Repeating symbols:

Please, pay attention to the following symbols throughout this document emphasizing particular information.

▲ **WARNING:** Identifies an instruction, which if not followed, may cause serious injury or even death.

■ **CAUTION:** Denotes an instruction which if not followed, may severely damage the engine or could lead to suspension of warranty.

◆ **NOTE:** Information useful for better handling.

1) Planning information

1.1) Engines affected

All versions of the engine type:

- 912 A from S/N 4,410.690
- 912 F from S/N 4,412.915
- 912 S from S/N 4,923.309
- 912 UL from S/N 4,407.860
- 912 ULS from S/N 5,646.560
- 912 ULSFR from S/N 4,430.311 to S/N 4,430.500 and from S/N 6,374.028
- 914 F from S/N 4,420.607
- 914 UL from S/N 4,419.316

All crankcase housings from S/N 06.0010 supplied as spare part or shortblock.

In addition, are also affected, all engines with crankcase part no. 888868 S/N 06.0010 or higher, has installed at engine repair / general overhaul.

1.2) Concurrent ASB/SB/SI and SL

none

1.3) Reason

Due to deviations during assembly operation, some isolated cases of slight oil leakage in the area of the cylinder barrel have been noted. For repair purposes additional a special gasket was created which seals this area.

1.4) Subject

Oil leakages in the area of the cylinder barrel for ROTAX® engine type 912 and 914 (Series).

1.5) Compliance

- In case of oil leaks in the area of the cylinder barrel in accordance with section 3.

▲ **WARNING:** Non-compliance with these instructions could result in engine damages, personal injuries or death.

1.6) Approval

The technical content is approved under the authority of DOA No. EASA.21J.048.

1.7) Manpower

Estimated man-hours:

engine installed in the aircraft - - - manpower time will depend on installation and therefore no estimate is available from the engine manufacturer.

cd02079

1.8) Mass data

change of weight - - - none
moment of inertia - - - unaffected

1.9) Electrical load data

no change

1.10) Software accomplishment summary

no change

1.11) References

In addition to this technical information refer to current issue of:

- Maintenance Manual (MM)

◆ NOTE: The status of Manuals can be determined by checking the table of amendments of the Manual. The 1st column of this table is the revision status. Compare this number to that listed on the ROTAX WebSite: www.rotax-aircraft-engines.com. Updates and current revisions can be downloaded for free.

1.12) Other publications affected

none

1.13) Interchangeability of parts

- all used parts which cannot be used must be returned F.O.B. to a ROTAX[®] Authorized Distributor or Service Center.

2) Material Information

2.1) Material - cost and availability

Price and availability will be supplied on request by ROTAX[®] Authorized Distributors or their Service Center.

2.2) Company support information

none

2.3) Material requirement per engine

◆ NOTE: repair by ROTAX[®] Authorized Distributors or their Service Center only.
- parts requirement for repair by ROTAX[®] Authorized Distributors or their Service Center.

Fig.no.	New p/n	Qty/engine	Description	Old p/n	Application
2	431411	8	gasket	-	cylinder barrel
	-	8	O-ring 87X2	250510	cylinder barrel
	-	8	O-ring 16X5	850930	oil return tube
	-	4	O-ring 105X2,5	250285	valve cover
	-	4	O-ring 6,4X1,8	430205	valve cover
	-	4	O-ring 34X2	230910	intake manifold

2.4) Material requirement per spare part

none

2.5) Rework of parts

none

2.6) Special tooling/lubricant-/adhesives-/sealing compound - Price and availability

Fig.no.	p/n	Qty/engine	Description	Old p/n	Application
	-	1	piston ring spanner 79,5	876978	piston 912/914
	-	1	piston ring spanner 84	876967	piston 912 ULS/S
	-	1	cylinder aligning tool	877262	cylinder head
	-	as required	cleaning agents	**	crankcase / cylinder

** e.g. brake cleaner or equivalent

3) Accomplishment/Instructions

Accomplishment

All the measures must be taken and confirmed by the following persons or facilities:

- ROTAX[®] -Airworthiness representative
- ROTAX[®] -Distributors or their Service Centers
- Persons approved by the respective Aviation Authority

▲ **WARNING:** Proceed with this work only in a non-smoking area and not close to sparks or open flames. Switch off ignition and secure engine against unintentional operation. Secure aircraft against unauthorized operation. Disconnect negative terminal of aircraft battery.

▲ **WARNING:** Risk of scalds and burns! Allow engine to cool sufficiently and use appropriate safety gear while performing work.

▲ **WARNING:** Should removal of a locking device (e.g. lock tabs, self-locking fasteners, etc.) be required when undergoing disassembly/assembly, always replace with a new one.

3.1) Instructions

■ **CAUTION:** All work has to be performed in accordance with the relevant Maintenance Manual.

3.1.1) Check for oil leaks

(see fig. 1 and 2)

Visually inspect the crankcase especially:

- in the area of the cylinder barrel (1)
- if you notice oil leaks in this area then the following work has to be performed.

◆ **NOTE:** If only a small amount of oil leakage is found, a ferry flight to a maintenance facility is permitted.

3.1.2) Removal of cylinder head

- remove exhaust springs and exhaust system.
- drain coolant from engine.
- remove screws from the intake manifolds.
- remove bottom spark plug connectors from ignition wires. Tape ID tags into place to avoid mixing ignition wires.
- remove screws from coolant elbows at the top of cylinder heads and remove coolant hoses from bottom elbows of cylinder heads.
- remove valve covers and cylinder head collar cap nuts.
- remove cylinder heads from all 4 cylinders.
- remove all cylinder stud bolts.
- move the piston of cylinder #1 to TDC and pull off the cylinder. Protect the conrod from damaging crankcase, do not allow conrod to strike case.

◆ **NOTE:** Complete removed of the cylinders is necessary for this work. Removal of the piston is not necessary.

- repeat the procedure on the remaining cylinders 2, 3 and 4.

◆ **NOTE:** While turning crankshaft make sure pistons move freely and do not contact crankcase.
- clean cylinder barrels and crankcase housing surface.

3.1.3) Installation of cylinder head

(see fig. 1 and 2)

- replace cylinder base O-ring 87X2 on all cylinders.
- move the piston of cylinder #1 to TDC.

◆ **NOTE:** While turning crankshaft make sure pistons move freely and do not contact crankcase.

- install cylinder with piston ring spanner 79.5 mm (876978 for ROTAX 912/914) or 84 mm (876967 for ROTAX 912 ULS/S).
- ◆ NOTE: Align piston ring end gaps in accordance with the relevant Maintenance Manual.
- With the position still at TDC pull cylinder away from crankcase about 13 mm (1/2 in.). Do not pull out over piston rings.
- install studs (7) with thread length of 28 mm (1.10 in.) with sealing gasket (2) into positions (3) with finger tight (3 Nm) (26 in.lb.).
- ◆ NOTE: At installation of the studs obey the different thread length. Thread length 20 mm (.79 in.) (5) must point in the direction of the cylinder head.
- ◆ NOTE: Install sealing gaskets only on the 2 left hand studs (3) of each cylinder.
- install studs (6) with unequal thread length of 20 mm (.79 in.) points in the direction of the cylinder head and the short threads of 15 mm (.59 in.) go into the hex. head inserts (4) with finger tight 3 Nm (26 in.lb) (see fig. 1 and 2).
- place pre-oiled new O-ring 16X5 onto oil return tubes.
- seat the cylinder centred positioned into the cylinder head and hold together while pushing into place. Tighten hex. nuts until cylinder base lightly touches crankcase.
- ◆ NOTE: Washers are not necessary for the tightening of these hex. nuts. But make sure that contact surface is lubricated with grease.
- ◆ NOTE: Ensure that the oil return tube o-rings seat into the crankcase.
- CAUTION: Make sure that no combustion residue enters into cylinder / cylinder head mating surface. This can result in leaks and overheating of components.
- repeat the procedure for cylinder 2,3 and 4.
- install cylinder aligning tool and tighten screws to 10 Nm (90 in.lb)
- torque collar cap nuts and hex. nuts gradually in a cross torque pattern to 22 Nm (195 in.lb) and remove cylinder aligning tool .
- place new O-ring in valve covers and place valve covers into position. Tighten allen screws M6X30 with washer. Tightening torque 10 Nm (90 in.lb).
- place upper coolant elbows into position and torque allen screw to tightening torque 10 Nm (90 in.lb).
- attach lower coolant hoses to cylinder heads.
- install intake manifolds and torque allen screws to tightening torque 10 Nm (90 in.lb).
- install resistance spark plug connectors.
- install exhaust system and exhaust springs.

- Restore aircraft to original operating configuration.
- Connect negative terminal of aircraft battery.

3.2) Test run

When operating the engine make sure that all necessary operating fluids (engine oil, coolant, fuel) are filled up to their specified levels!

Conduct test run including ignition check and leakage test in accordance with the current Maintenance Manual of the respective engine type.

- CAUTION: If any leakages in the area of the cylinder barrel are evident, the cause has to be found. Do not tighten again the cylinder or tighten with increased tightening torque.

3.3) Summary

These instructions (section 3) have to be conducted in accordance with compliance in section 1.5.

- ▲ WARNING: Non-compliance with these instructions could result in engine damage, personal injury or death!

Approval of translation to best knowledge and judgement - in any case the original text in German language and the metric units (SI-system) are authoritative.

4) Appendix

the following drawings should convey additional information:

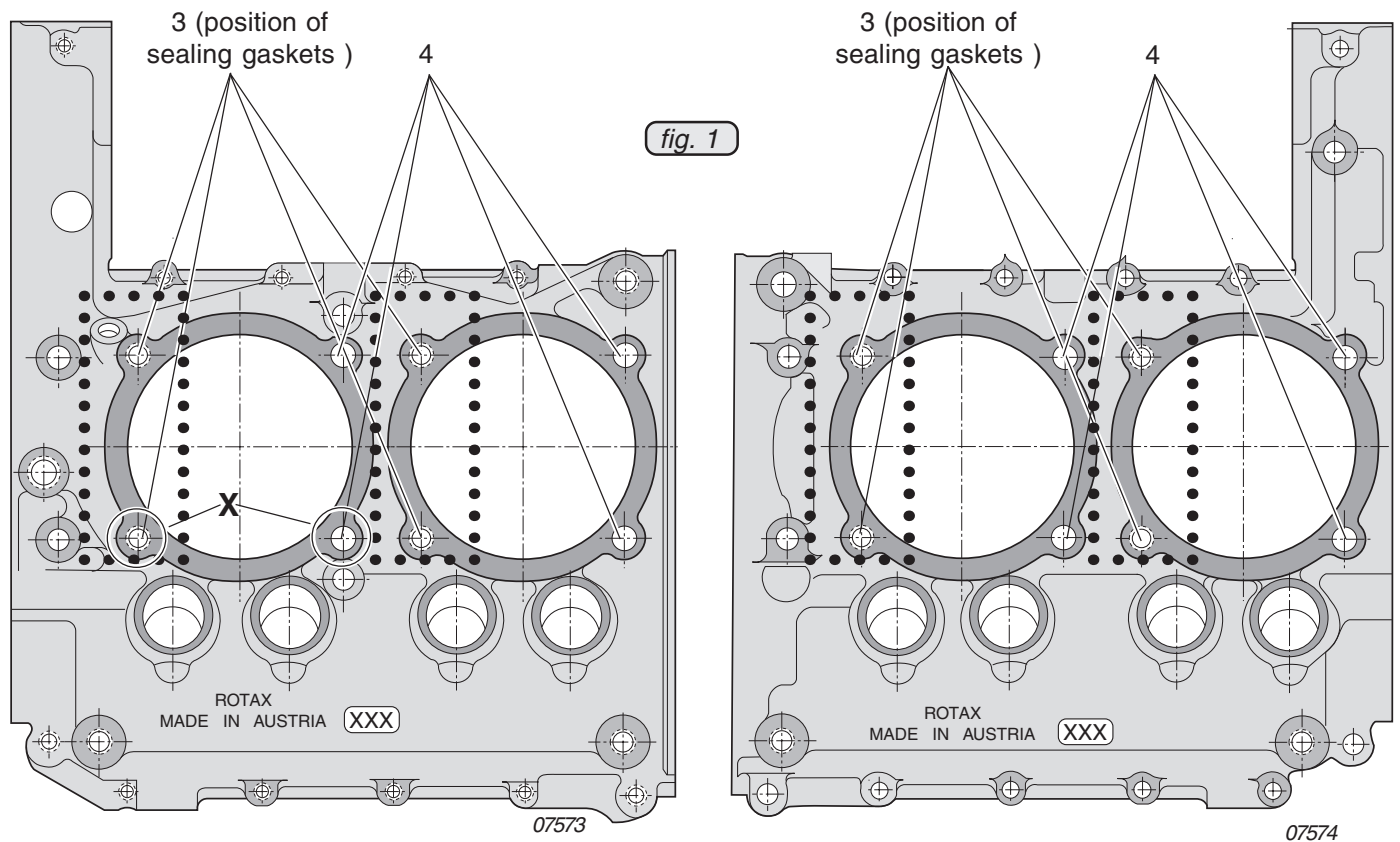

• • • • position of sealing gaskets on the left hand studs

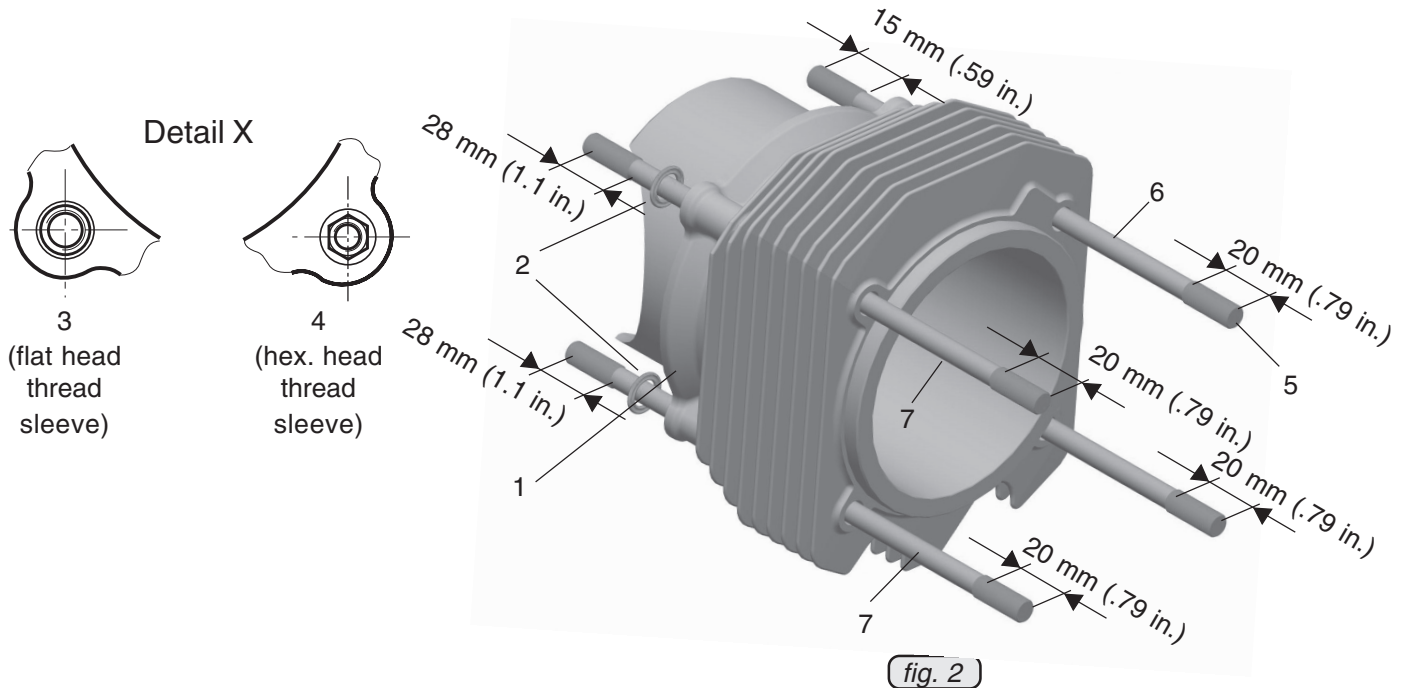

◆ NOTE: The illustrations in this document show the typical construction. They may not represent full detail or the exact shape of the parts which have the same or similar function. Exploded views are **no technical** drawings and are for reference only. For specific detail, refer to the current documents of the respective engine type.